

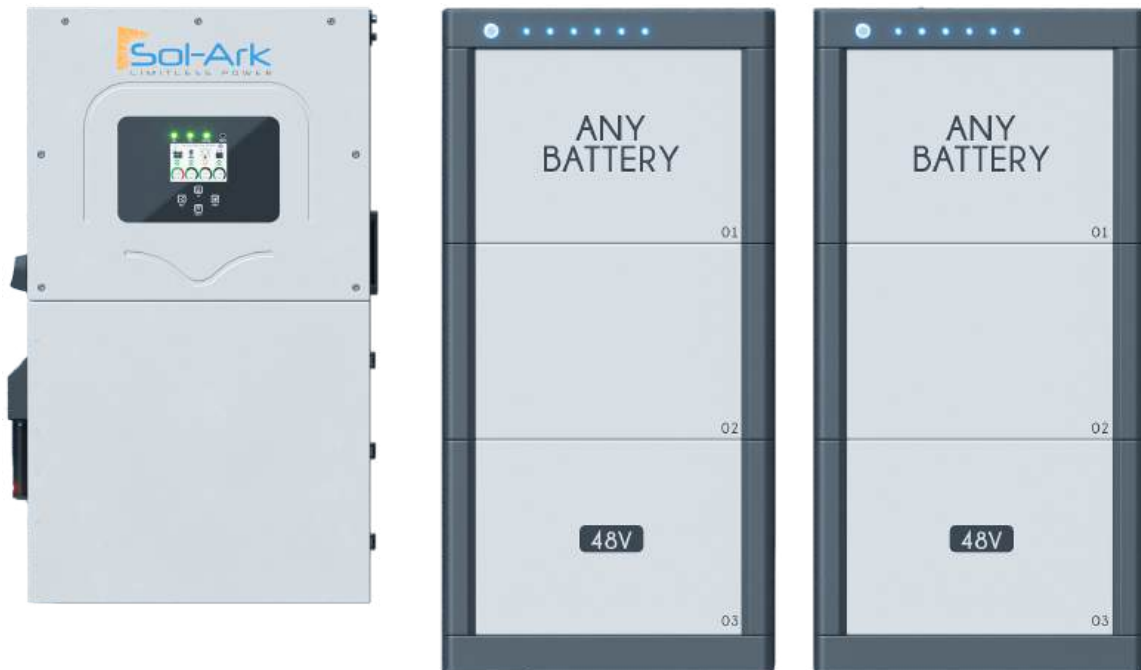

BATTERY INTEGRATION GUIDE



LOW VOLTAGE 48V - RESIDENTIAL



DISCLAIMER

This document is a Battery Integration Guide that offers general information on configuring various lithium batteries to operate seamlessly with Sol-Ark hybrid inverter products. Please note that in-depth configurations, step by step instructions, troubleshooting and verification of operational parameters extend beyond the scope of this document. As such, users are strongly advised to refer to the comprehensive technical documentation provided by the battery manufacturer for detailed specifications and recommended settings for optimal performance and safety.

Furthermore, due to the evolving nature of battery technologies, new features, requirements, or compatibility considerations may arise. Users should stay informed about the latest developments and recommendations from both Sol-Ark and the battery manufacturer. While this document serves as a valuable resource, it should supplement rather than replace diligent reference to manufacturer documentation and, if necessary, consultation with qualified technical specialists to ensure the seamless integration and optimal performance of energy storage systems with Sol-Ark hybrid inverters.

This guide is only for Low-Voltage Hybrid Inverters.

For support, contact:

(USA) +1 (972) 575-8875 ext. (2)

support@sol-ark.com

Table of Contents

General Hardware Configuration	4
Sol-Ark 15K-2P-N	4
Sol-Ark 12K / 8K / 5K (Outdoor)	5
Sol-Ark 12K Legacy (Indoor)	6
Sol-Ark 8K Legacy (Indoor)	7
CAN Bus Battery Screen	8
Modbus/RS-485 Battery Screen	8
Compatible Batteries	9
1. BLUE PLANET ENERGY	9
1.1 Blue Ion/eGauge	9
1.2 Blue Ion/Namaka	10
2. BRIGGS&STRATTON AmpliPhi	11
3. Deka-Duration-DD5300 (low voltage e.g. 48vdc mode)	12
4. Discover	13
5. Dyness	14
6. EndurEnergy ESP-5100	15
7. FORTRESS POWER	16
7.1 FORTRESS eFlex 5.4 (kWh)	16
7.2 FORTRESS eVault & eVault MAX 18.5 (kWh)	17
8. HOMEGRID Stack'd	18
9. Incell / Polarium	19
10. KILOVAULT HAB	20
11. NuEnergy	21
11.1 NuEnergy Lithium	21
11.2 NuEnergy Lithium- Power Base M50	22
12. POWERSYNC 51.2V Lithium	23
13. PYLONTECH US3000C	24
14. Pytes E-BOX-48100R	25
15. RENOGY AURA	26
16. SACRED SUN LFP	27
17. SOK	28
18. STORZ POWER	29
19. UZ ENERGY Power Lite (L051100-B)	30
20. Volthium Energy	31



This document covers battery integration with Sol-Ark's low-voltage hybrid inverters. For Modbus RS-485 communication reliability, update to the latest firmware version, with Comm v143F or greater.

General Hardware Configuration

Sol-Ark 15K-2P-N



The Sol-Ark 15K-2P-N inverter achieves battery communications through a single RJ-45 port labeled “Battery CANBus”. This port combines the Modbus and CAN bus pin configurations shown below. Both “Modbus RS485” and “Battery CANBus” ports are capable of Modbus communication.

The following figure shows the communication board inside the wiring area of the 15K inverter. Please note that only the “Battery CANBus” port is used for battery communications. The pin configurations for Modbus and CAN bus communication of this RJ-45 are shown in the table below.

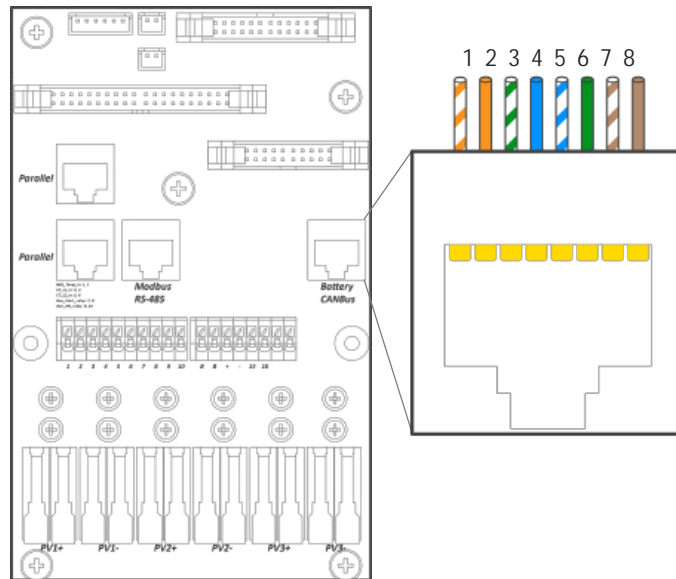

15K-2P-N comm board and “Battery CANBus” communication port

TABLE I
PIN CONFIGURATIONS OF “BATTERY CANBUS” PORT FOR MODBUS & CAN BUS PROTOCOLS

Pin	Battery CAN Bus Port	
	Modbus	CAN Bus
1	RS-485 A+	--
2	RS-485 B-	--
3	--	--
4	--	CAN Hi
5	--	CAN Lo
6	GND	GND
7	RS485 A+	--
8	RS485 B-	--

Sol-Ark 12K / 8K / 5K (Outdoor)



The Sol-Ark Outdoor-Rated inverter (12K-2P, 8K-2P and 8K-2P) achieve battery communications through a single RJ-45 port labeled “Battery CANBus”. This port combines the Modbus and CAN bus pin configurations shown below. Both “Modbus RS485” and “Battery CANBus” ports are capable of Modbus communication.

The following figure shows the communication board inside the wiring area of the 12K / 8K / 5K inverters. Please note that only the “Battery CANBus” port is used for battery communications. The pin configurations for Modbus and CAN bus communication of this RJ-45 are shown in the table below.

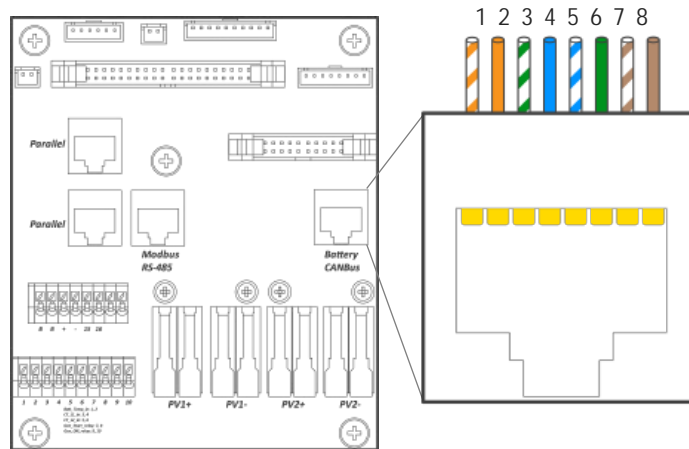

12K / 8K / 5K comm board and “Battery CANBus” communication port

TABLE II
PIN CONFIGURATIONS OF “BATTERY CANBUS” PORT FOR MODBUS & CAN BUS PROTOCOLS

Pin	Battery CAN Bus Port	
	Modbus	CAN Bus
1	RS-485 B-	--
2	RS-485 A+	--
3	--	--
4	--	CAN Hi
5	--	CAN Lo
6	GND	GND
7	RS485 A+	--
8	RS485 B-	--

 The outdoor-rated systems and Sol-Ark 15K inverters have a “Modbus RS-485” port, which is not for battery communications.

Sol-Ark 12K Legacy (Indoor)



The Sol-Ark 12K Indoor can communicate through two RJ-45 ports labeled “CAN” and “RS-485”. Battery communication is established through CAN bus or Modbus communication protocols through the “CAN” and “RS-485” ports respectively

The following figure shows the communication board inside the wiring area of the 12K Indoor inverter. Note that both the “CAN” and “RS-485” ports can be used for battery communications depending on the required protocol. The pin configurations for Modbus and CAN bus communications are shown in the table below.

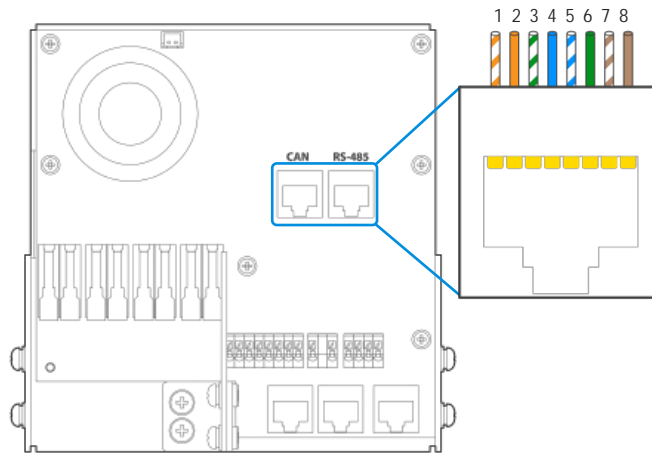

12K Indoor comm board and battery “CAN” & “RS-485” communication ports

TABLE III
PIN CONFIGURATIONS OF “CAN” & “RS-485” PORTS FOR CAN BUS & MODBUS PROTOCOLS

Pin	CAN (CAN Bus)	RS-485 (Modbus)
1	--	RS-485 B-
2	--	RS-485 A+
3	--	--
4	CAN Hi	--
5	CAN Lo	--
6	GND	GND
7	--	RS485 A+
8	--	RS485 B-

Sol-Ark 8K Legacy (Indoor)



The Sol-Ark 8K Indoor can communicate through two RJ-45 ports labeled “RJ45_485” and “RJ45_CAN”. Battery communication is established through CAN bus or Modbus communication protocols through the “RJ45_485” and “RJ45_CAN” ports respectively

The following figure shows the communication board inside the wiring area of the 8K Indoor inverter. Note that both the “RJ45_485” and “RJ45_CAN” ports can be used for battery communications depending on the required protocol. The pin configurations for Modbus and CAN bus communications are shown in the table below

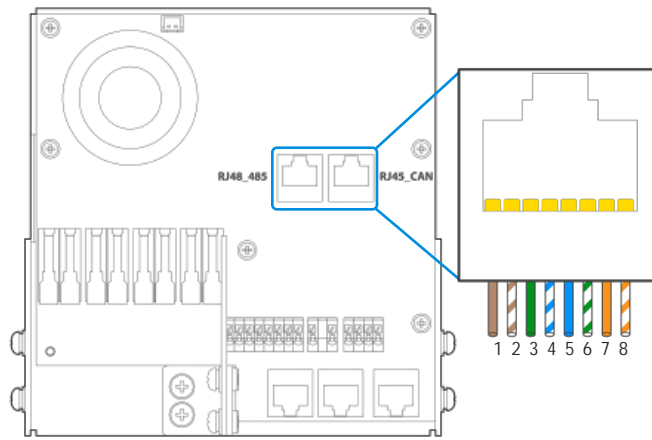

8K Indoor comm board and battery “RJ45_485” & “RJ45_CAN” communication ports

TABLE IV
PIN CONFIGURATIONS OF “RJ45_485” & “RJ45_CAN” PORT FOR MODBUS AND CAN BUS PROTOCOLS

Pin	RJ45_485 (Modbus)	RJ45_CAN (CAN Bus)
1	RS-485 B-	--
2	RS-485 A+	--
3	--	--
4	--	CAN Hi
5	--	CAN Lo
6	GND	GND
7	RS485 A+	--
8	RS485 B-	--

CAN Bus Battery Screen

The image below depicts the “LI Batt Info” screen when communications are enabled for CAN Bus batteries (“BMS Lithium Batt 00”).

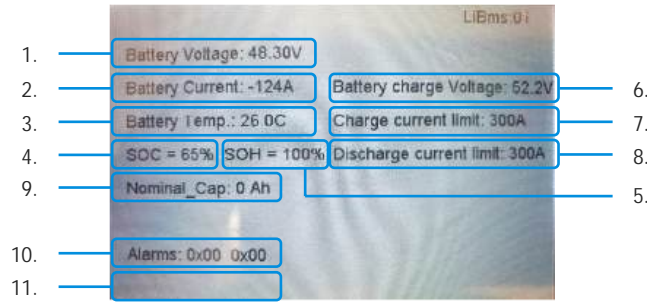

1. Battery Voltage: Real-time voltage measured between the battery terminals.
2. Battery Current: Real-time current flowing into or out of battery's + terminal. (negative / positive sign respectively).
3. Battery Temp: Real-time temperature measured at the BMS.
4. SOC: State of charge remaining in the battery according to the BMS.
5. SOH: State of health of the battery according to the BMS.
6. Battery Charge Voltage: The inverter should charge the battery to the maximum voltage.
7. Charge Current Limit: Maximum allowable current into the battery.
8. Discharge Current Limit: Maximum allowable current out of the battery.
9. Nominal_Cap: Amp-hour design capacity of the battery (not used on all batteries).
10. Alarms: Displays any alarm codes from the battery (manufacturer specific).
11. Force Charge Request: Command sent by the BMS telling the inverter to charge the battery from any available power source regardless of inverter settings. Not shown in the above image but would be located below the “Alarms” field.

Modbus/RS-485 Battery Screen



As of Mar 16, 2023, Sol-Ark recommends that if establishing communication via Modbus RS485, make sure to have the inverter firmware upgraded to the latest available version, with Comm v143F or higher and the latest primary and follower MCU versions.

The image below depicts the “LI Batt Info” screen when communicating via Modbus/RS-485 (All other “BMS Lithium Batt” modes).

1.	2.	3.	4.	5.
55.91 V	0.00 A	23.5 C	100%	208Ah
56.0V	48.0V	200A	208A	0x00 0x00
6.	7.	8.	9.	10.
0.00 V	0.00 A	0.0 C	0.0%	0.0Ah
0.00 V	0.00 A	0.0 C	0.0%	0.0Ah
0.00 V	0.00 A	0.0 C	0.0%	0.0Ah
0.00 V	0.00 A	0.0 C	0.0%	0.0Ah
0.00 V	0.00 A	0.0 C	0.0%	0.0Ah
0.00 V	0.00 A	0.0 C	0.0%	0.0Ah
0.00 V	0.00 A	0.0 C	0.0%	0.0Ah
0.00 V	0.00 A	0.0 C	0.0%	0.0Ah
0.00 V	0.00 A	0.0 C	0.0%	0.0Ah
0.00 V	0.00 A	0.0 C	0.0%	0.0Ah
0.00 V	0.00 A	0.0 C	0.0%	0.0Ah
0.00 V	0.00 A	0.0 C	0.0%	0.0Ah
0.00 V	0.00 A	0.0 C	0.0%	0.0Ah
0.00 V	0.00 A	0.0 C	0.0%	0.0Ah

1. Battery Voltage: Real-time voltage measured between the battery terminals.
2. Battery Current: Real-time current flowing into or out of battery's + terminal. (negative / positive sign respectively).
3. Battery Temp: Real-time temperature measured at the BMS.
4. SOC: State of charge remaining in the battery according to the BMS.
5. Total Capacity: Total Amp-Hour capacity connected to the inverter. Not present for all batteries.
6. Battery Charge Voltage: The inverter should charge the battery to the maximum voltage.
7. Battery Empty Voltage: Minimum voltage the inverter should discharge the battery to.
8. Charge Current Limit: Maximum allowable current into the battery.
9. Discharge Current Limit: Maximum allowable current out of the battery.
10. Alarms: Displays any alarm codes from the battery (manufacturer specific).
11. Battery Data Chart: This table displays individual information from each connected battery up to a maximum of 12 batteries. Not all manufacturers utilize this feature.



Line one (1) is never populated for any manufacturer. The first battery is always displayed on line two (2).

Compatible Batteries

1. BLUE PLANET ENERGY



The provided information serves as general setup instructions for Blueplanet batteries and Sol-Ark inverters. Users are strongly advised to **consult the comprehensive technical documentation** provided by **Blueplanet** and **eGauge** for specifications and settings to ensure optimal performance and safety. Visit the manufacturer's website and consult the relevant documentation below.



BluePlanet documentation



eGauge documentation

1.1 Blue Ion/eGauge



The Sol-Ark will need an eGauge monitoring device, an eGauge USB-485 converter, and a wired internet connection to establish communications with the Blue Ion battery.

You will need a custom RJ45 cable for this setup.

Communications Installation and Setup Instructions

1. Connect the Blue Ion to your wired internet connection using the RJ45 port on the back of the unit.
2. Connect the eGauge to a power source.
3. Connect the eGauge to your wired internet connection using the RJ45 port on the unit.
4. Follow the instructions from eGauge to set up the device with your Blue Ion battery.
5. Connect the USB-485 to the eGauge.
6. Set up the USB-485 using eGauge's online instructions.
7. Enable Modbus RTU on the eGauge.
8. Connect "D+" on the USB-485 to either pin two (2) or pin seven (7).
9. Connect "D-" to either pin one (1) or pin eight (8).
10. GND to either pin three (3) (indoor units only) or pin six (6) (indoor and outdoor units).



eGauge needs to configure your device specifically for use with the Sol-Ark. Please verify this by getting in touch with eGauge support

11. Plug the RJ45 cable into the "RS-485" (indoor models) or "Battery CAN Bus" (outdoor models) port on the inverter.
12. Program the inverter with this battery's appropriate charge/discharge settings.
13. Enable "BMS Lithium Batt" and set its value to "03."
14. (Optional) Turn on "BMS_Err_Stop" if you wish for the system to fault on the loss of battery communications

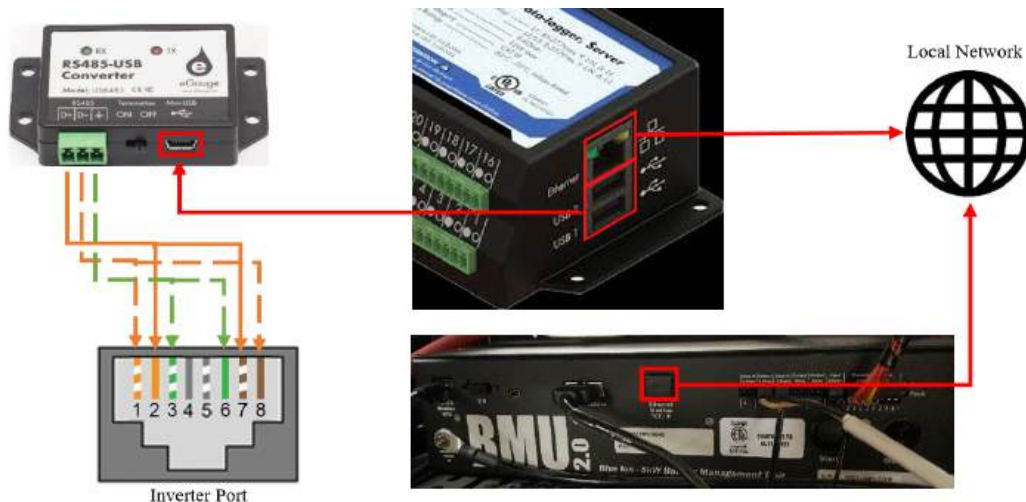

1.2 Blue Ion/Namaka



The provided information serves as general setup instructions for Blueplanet batteries and Sol-Ark inverters. Users are strongly advised to **consult the comprehensive technical documentation** provided by **Bluplanet** and **Namaka** for specifications and settings to ensure optimal performance and safety. Visit the manufacturer's website and consult the relevant documentation below.



BluePlanet documentation



The Sol-Ark will need a Namaka monitoring device and a wired internet connection to communicate with the Blue Ion battery.

Communications Installation and Setup Instructions

1. Connect all Blue Ion cabinets using their “RS-485 Modbus RTU” ports and standard RJ45 ethernet cable.
2. Connect the daisy-chained cabinets to the Namaka’s “BMU” port using a standard RJ45 ethernet cable.
3. Connect the ethernet port on the Namaka to an active, wired internet connection using a standard RJ45 ethernet cable.
 - a. Some Namaka units may be configured for Wireless or no internet connection. Contact Blue Ion for further information.
4. Connect the 12V power connection from the Namaka to the nearest Blue Ion BMU.
5. Connect the “BMS” port on the Namaka to the inverter’s “Battery CAN Bus” port (outdoor units only) or to the “CAN” port (indoor units only).
6. Program the inverter with this battery's appropriate charge/discharge settings.
7. Power on the Namaka by flipping the DC breaker in the unit’s enclosure.
8. Enable “BMS Lithium Batt” and set its value to “00”.
9. (Optional) Turn on “BMS_Err_Stop” if you wish for the system to fault on the loss of battery communications

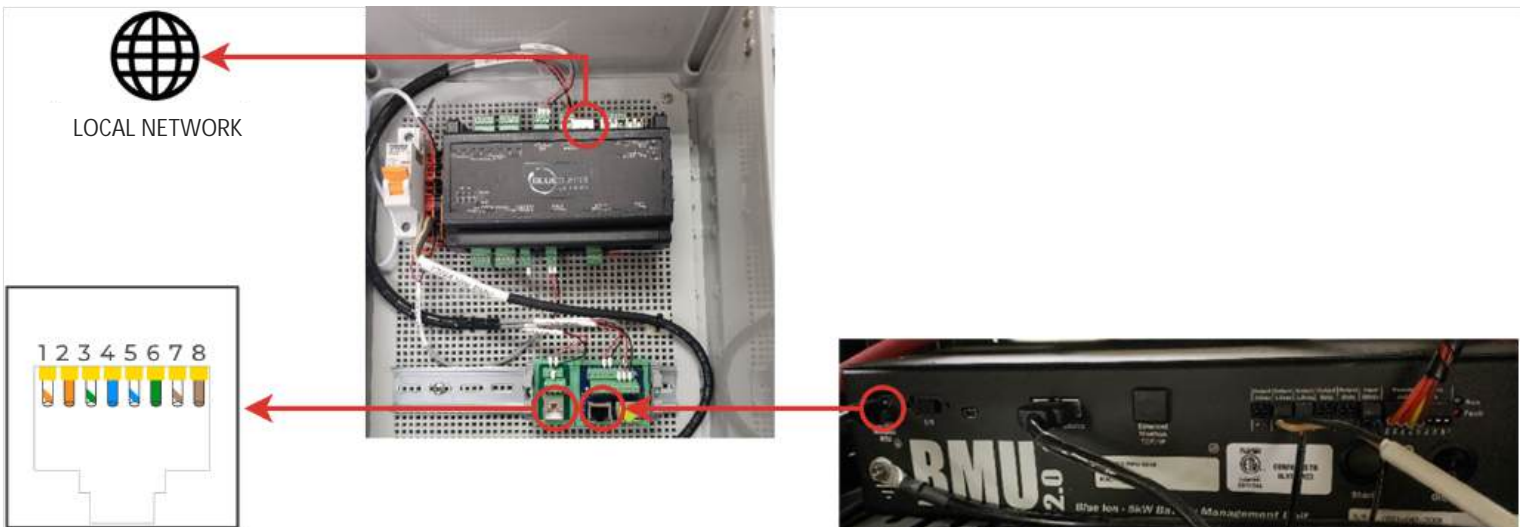

2. BRIGGS&STRATTON AmpliPhi



The provided information serves as general setup instructions for Briggs&Stratton batteries and Sol-Ark inverters. Users are strongly advised to **consult the comprehensive technical documentation** provided by **Briggs&Stratton** for specifications and settings to ensure optimal performance and safety. Visit the manufacturer's website and consult the relevant documentation below.



[Briggs&Stratton integration guide](#)

Communications Installation and Setup Instructions

1. Connect all batteries using the included RJ45 cables, using the two ports nearest to each other to bridge the batteries together (GREEN in the picture below).
2. Use the included 120 Ohm terminators on both ends of the resulting chain.
3. Use either the battery from the beginning or the end of the chain. Connect an RJ45 cable from the separate RJ45 port (RED in the picture below) to the "CAN" or "Battery CAN Bus" port on the inverter.
4. Program the inverter with this battery's appropriate charge/discharge settings.
5. Enable "BMS Lithium Batt" and set its value to "00."
6. (Optional) Turn on "BMS_Err_Stop" if you wish the system could fault on battery communications loss

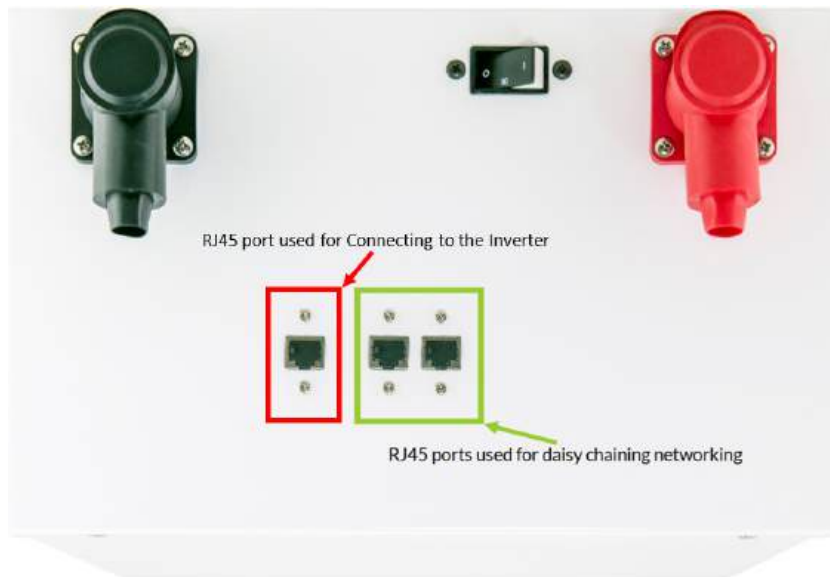

3. Deka-Duration-DD5300 (low voltage e.g. 48vdc mode)



The provided information serves as general setup instructions for Deka batteries and Sol-Ark inverters. Users are strongly advised to **consult the comprehensive technical documentation** provided by Deka for specifications and settings to ensure optimal performance and safety. Visit the manufacturer's website and consult the relevant documentation below.



[Deka documentation](#)

- Please ensure that you are not wiring to the High Voltage connection terminals of the Deka-DD5300 battery.
- Please refer to the Installation & Operation (I&O) manual of the battery manufacturer and verify the proper communications configuration of CAN bus connections and dip switch settings:
- A custom cable is required to establish communications with Deka-DD5300 batteries.

Communications Installation and Setup Instructions

1. Create a custom cable that connects battery pins 1, 2, and 3 ONLY (white-orange, solid orange, and white-green).
2. Pin 3 (white-green) should connect to pin 6 on the inverter.
3. Pin 1 (white-orange) should connect to pin 4 on the inverter. Pin 2 (solid orange) should connect to pin 5 on the inverter.
 - On indoor units, connect pin 3 (white-green) to pin 2 on the inverter instead of pin 6.
4. Connect the cable to the "CAN-A" port on the Deka-DD5300 and the "Battery CAN Bus" port (or the "CAN" port for indoor-only units) on the Sol-Ark.
 - The cable is NOT reversible; therefore, keep track of which end of the custom cable connects to the battery and the Sol-Ark.
5. Turn on the mechanical POWER SWITCH to enable the BMS on all battery modules.
6. Press and hold the RUN BUTTON for 2 seconds only on the MASTER battery module, and allow other modules to turn themselves on automatically. After a successful startup of the battery modules, the LED status indicator should turn solid green.
7. Program the inverter with this battery's appropriate charge/discharge settings.
8. Enable "BMS Lithium Batt" and set its value to "00."
9. (Optional) Turn on "BMS_Err_Stop" if you wish for the system to fault on the loss of battery communications.

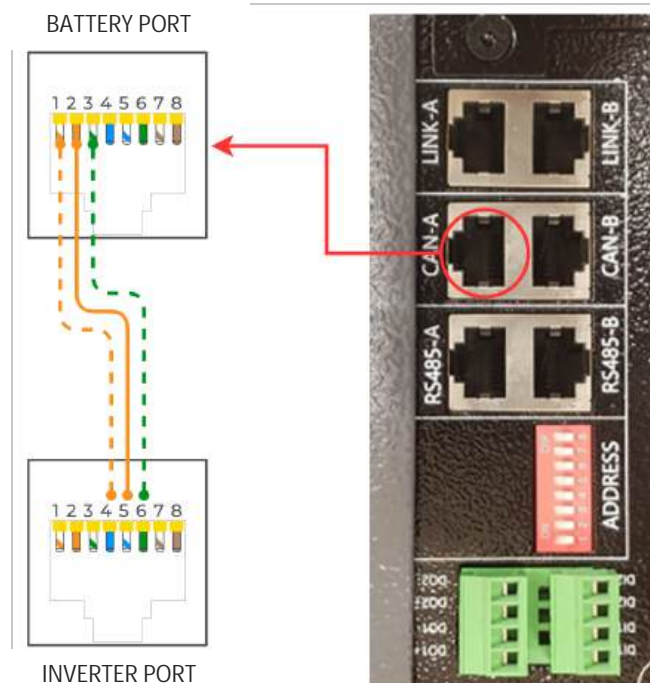

4. Discover

Discover[®]



The provided information serves as general setup instructions for Discover batteries and Sol-Ark inverters. Users are strongly advised to **consult the comprehensive technical documentation** provided by Discover for specifications and settings to ensure optimal performance and safety. Visit the manufacturer's website and consult the relevant documentation below.



Discover documentation



You will need the Discover Lynk device to adapt the battery's AEBus to CAN Bus for use with the Sol-Ark. The Lynk will need the proper adapter for the Sol-Ark's pin configuration (Part number 950-0016-SLRK).

Communications with this battery will require a custom cable (outdoor-rated units only)

Communications Installation and Setup Instructions

1. Insert the included RJ45 splitters into the AEBus port of each Discover Battery.
2. Connect and link each battery to the next in a chain using RJ45.
3. Connect either end of the chain of the batteries to the AEBus RJ45 port on the Lynk.
4. Connect the 12V power supply to one of the batteries and plug it into the other end of the chain using an RJ45 cable.
5. Connect the Edge Card's RJ45 port to the CAN Bus port of the Sol-Ark.
6. For outdoor-rated units only, create a custom RJ45 cable that connects pins four (4) (solid blue) and five (5) (white-blue) through to the same pins on the inverter and connects pin two (2) (solid orange) on the LYNK side to pin six (6) on the inverter.
7. You may use an off-the-shelf ethernet cable for indoor-rated units – no custom cable is needed.
8. Program the inverter with this battery's appropriate charge/discharge settings.
9. Enable "BMS Lithium Batt" and set its value to "00."
10. (Optional) Turn on "BMS_Err_Stop" if you wish the system could fault on battery communications loss.

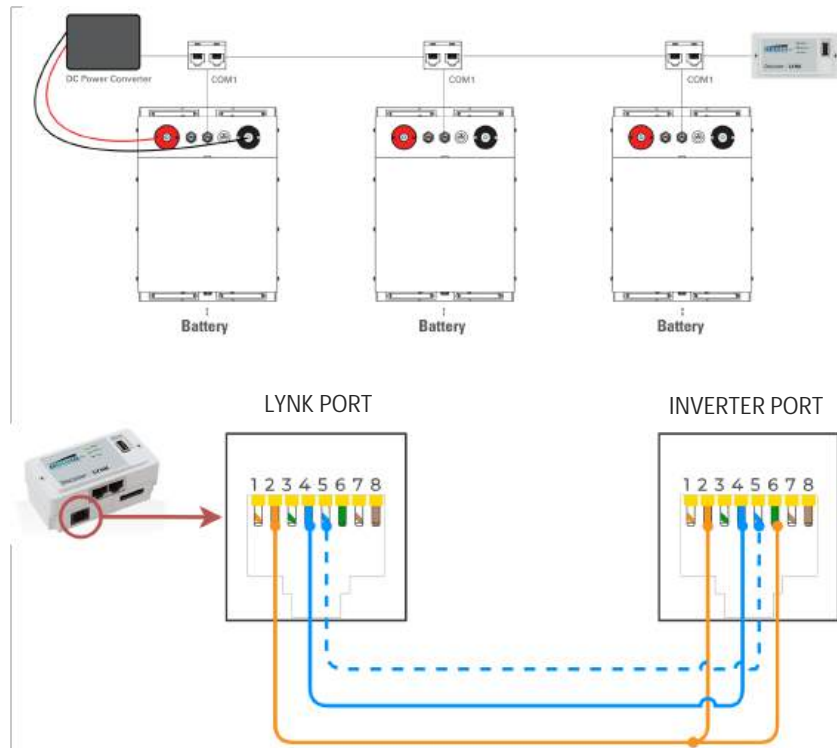

5. Dyness



The provided information serves as general setup instructions for Dyness batteries and Sol-Ark inverters. Users are strongly advised to **consult the comprehensive technical documentation** provided by Dyness for specifications and settings to ensure optimal performance and safety. Visit the manufacturer's website and consult the relevant documentation below.



Dyness documentation



Communications with this battery will require a custom cable (outdoor-rated units only)

Communications Installation and Setup Instructions

1. Ensure correct battery interconnection and connect to the inverter as specified in Dyness' user manual.
2. For outdoor-rated systems only, create a custom RJ45 cable that connects pin two (2) on the battery to pin six (6) on the inverter.
3. Connect one of the batteries to the inverter via the CAN Bus port.
4. Set the switch in position three (3) on the DIP selection switches to the "ON" position for the battery connected to the inverter.
5. Program the inverter with this battery's appropriate charge/discharge settings.
6. Enable "BMS Lithium Batt" and set its value to "00."
7. (Optional) Turn on "BMS_Err_Stop" if you wish the system could fault on battery communications loss.

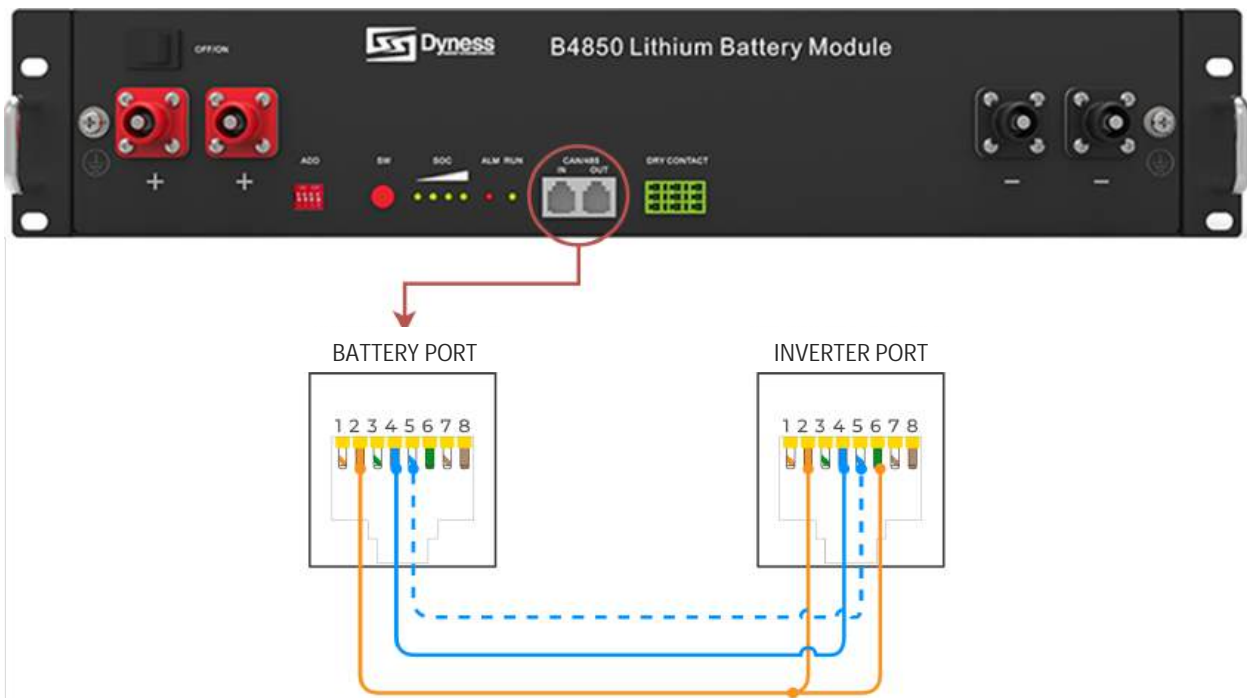

6. EndurEnergy ESP-5100



EndurEnergy Systems, Inc.



The provided information serves as general setup instructions for EndurEnergy batteries and Sol-Ark inverters. Users are strongly advised to **consult the comprehensive technical documentation** provided by EndurEnergy for specifications and settings to ensure optimal performance and safety. Visit the manufacturer's website and consult the relevant documentation below.



EndurEnergy documentation

Communications Installation and Setup Instructions

1. Connect all EndurEnergy ESP-5100 batteries together with the provided RJ45 cable using "M/S" ports. (Can use up to 8 batteries in 48V low voltage configuration)
2. Set all the dip switches according to the battery manual and double-check all dip switches on all batteries in the battery bank.
3. Connect a standard CAT5/6 cable to the "Inverter" port on the ESP-5100 Master battery, and the "Battery CAN Bus" port (or the "CAN" port for indoor-only units) on the Sol-Ark.
4. Program the inverter with the appropriate charge/discharge settings according to the specific battery manual and cable arrangement.
5. Enable "BMS Lithium Batt" and set its value to "00".
6. (Optional) Turn on "BMS_Err_Stop" if you wish for the system to fault on the loss of battery communications.

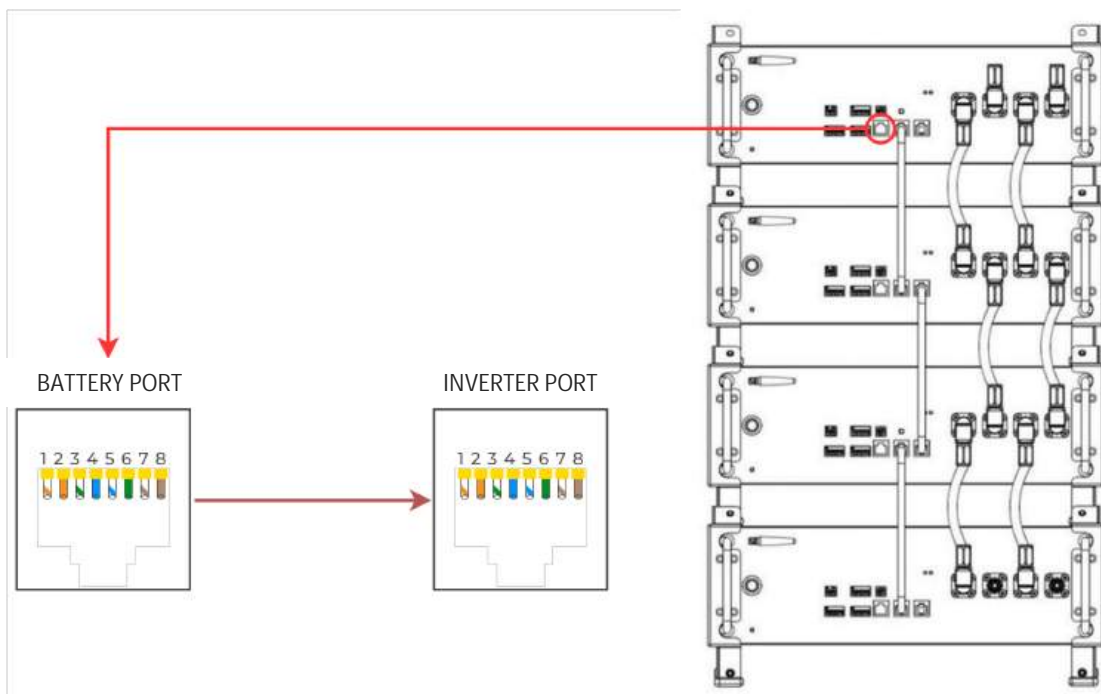

7. FORTRESS POWER



The provided information serves as general setup instructions for Fortress Power batteries and Sol-Ark inverters. Users are strongly advised to **consult the comprehensive technical documentation** provided by **Fortress Power** for specifications and settings to ensure optimal performance and safety. Visit the manufacturer's website and consult the relevant documentation below.



Fortress eFlex documentation

7.1 FORTRESS eFlex 5.4 (kWh)



You will need a custom RJ45 cable for this setup.



Sol-Ark and Fortress recommend CAN mode (Jan 2023) OR if you only have a cable for Modbus RS485, ask for an inverter firmware update to Comm v143F, which adds communication reliability

Comm Installation and Setup Instructions: Modbus RS485 or CAN mode

1. Connect all batteries using the included RJ45 cables.
2. Use the included 120 Ohm termination resistor on either end of the resulting chain. Select one of two options in the next step.
3. Option1: To establish CAN comm, create a custom cable starting with a CAT5 RJ45 cable where only
4. pins 4 (solid blue CANHigh), 5 (white-blue CANLow), and 6 (solid green GND) remain connected in their original positions, as shown in the pinouts picture below at RIGHT.
5. Option2: OR for Modbus RTU RS-485 create a custom CAT5 RJ45 cable where only
6. pins 6 (solid green gnd), 7 (white-brown RS485+), and 8 (solid brown RS485-) remain connected in their original positions, as shown in the picture below at left pinouts.
7. Using a CAT5/CAT6, also known as ethernet cable, that is known to work is more accessible and less prone to error. Cut open the cable and cut the unnecessary wires.



If you are crimping new connectors to create a cable, be careful not to over-tighten the crimping tool, as this can recess the connectors and lead to poor or intermittent connection.

8. Plug one end of the cable into the battery's CAN / RS485 port and the
9. other end (CAN mode): to inverter's CAN/"Battery CAN Bus" port. OR (RS485 mode): to inverter's "RS-485" port (indoor models) or outdoor: battery CAN Bus port
10. Program the inverter with this battery's appropriate charge/discharge settings. See manual.
11. Enable "BMS Lithium Batt" and set its value to "04" for RS485 or "00" for CAN mode.
12. (Optional) Turn on "BMS_Err_Stop" if you wish for the system to fault and stop battery current on the loss of battery communications.

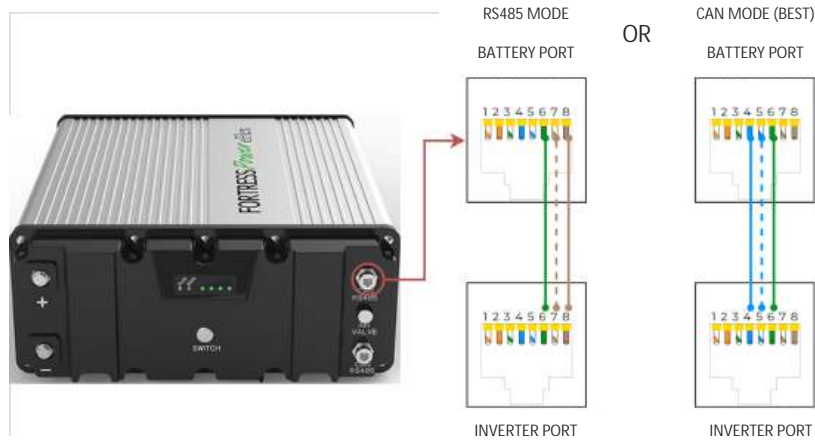

7.2 FORTRESS eVault & eVault MAX 18.5 (kWh)



The provided information serves as general setup instructions for Fortress Power batteries and Sol-Ark inverters. Users are strongly advised to **consult the comprehensive technical documentation** provided by **Fortress Power** for specifications and settings to ensure optimal performance and safety. Visit the manufacturer's website and consult the relevant documentation below.



[Fortress eVault documentation](#)



You will need a custom RJ45 cable for this setup.



Sol-Ark and Fortress recommend CAN mode (Jan 2023) OR if you only have a cable for Modbus RS485, ask for an inverter firmware update to COMM v143F, which adds communication reliability

Comm Installation and Setup Instructions

1. If using multiple batteries, designate one as the leader and the others as followers per Fortress' instructions. If using a single battery, skip to Step 3.
2. Connect multiple batteries by ethernet cable (RJ45 CAT5/CAT6 cable) as in Fortress' setup instructions.
3. Create a custom cable connecting battery side pins 1, 2, and 3 ONLY (CAN mode) or 3, 5, and 6 ONLY (Modbus RS-485):
 - If using CAN mode, Pin 1 (white-orange) should connect to Pin 4 (CAN H), Pin 2 (orange) should connect to Pin 5 (CAN L), and Pin 6 should be the same on the inverter end.
 - If using Modbus mode, Pin 3 (white-green) can connect to pin 2 or pin 7 (RS485+) on the inverter end, and Pin 5 (white-blue) can be connected to either pin 1 or 8 (RS485-) on the inverter end. Connect this cable between the Fortress eVault's CAN port (CAN mode) or RS485 port (Modbus mode) and the "Battery CANBus" port (Outdoor units) or the "CAN" (CAN mode) or "RS-485" port (Modbus mode, Indoor units).
4. Program inverter with appropriate charge/discharge settings for this battery. Program eVaultMAX or eVault as if you are operating in open loop. See inverter manual Fortress Battery eVault 18.5 settings.
5. Enable "BMS Lithium Batt" and set its value to "00" (CAN mode) or "04" (Modbus mode).
6. (Optional) Turn on "BMS_Err_Stop" if you wish for the system to fault on the loss of battery communications

1. eVault MAX RS-485

2. eVault MAX CAN MODE

3. eVault Classic RS-485

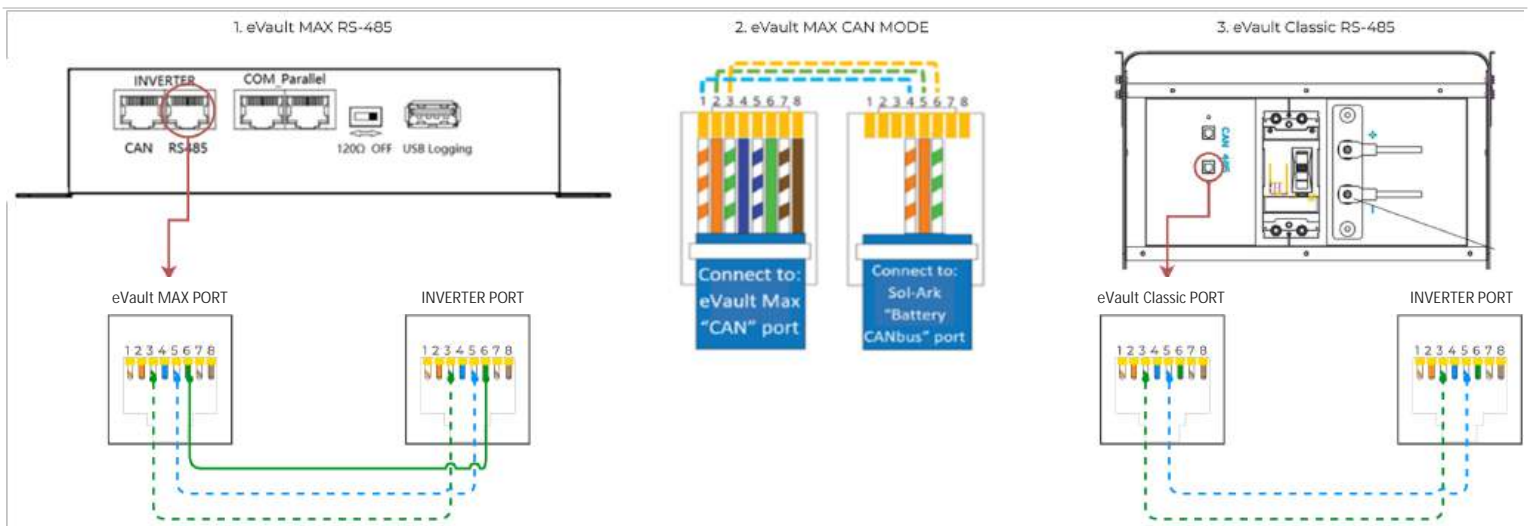

8. HOMEGRID Stack'd

HOMEGRID



The provided information serves as general setup instructions for Homegrid batteries and Sol-Ark inverters. Users are strongly advised to **consult the comprehensive technical documentation** provided by Homegrid for specifications and settings to ensure optimal performance and safety. Visit the manufacturer's website and consult the relevant documentation below.



[Homegrid Stack'd documentation](#)



You will need a custom RJ45 cable for this setup.

Communications Installation and Setup Instructions

1. Set the DIP switches on each battery according to the manufacturer's manual.
2. Connect all top modules (if in parallel) together with RJ45 cable between their "Link A" and "Link B" ports. It does not matter which port is connected to which.
3. Create a custom cable that connects pins 6, 7, and 8 ONLY (solid-orange, white-green, and solid-blue) to the battery.
4. Pin 6 (solid-green) needs to connect to pin 6 on the inverter.
5. Pin 7 (white-brown) needs to connect to pin 4 on the inverter.
6. Pin 8 (solid-brown) needs to connect to pin 5 on the inverter.
 - On indoor units, pin 6 (solid-green) needs to connect to pin 2 on the inverter.
7. Connect the cable between the master battery's top module and the inverter's "Battery CANBus" (Outdoor models) or "CAN" (Indoor models) port.
8. Power on the battery units by turning on each module, followed by that stack's top module.
9. Program the inverter with this battery's appropriate charge/discharge settings.
10. Enable "BMS Lithium Batt" and set this value to "00".
11. (Optional) Turn on "BMS_Err_Stop" if you wish the system could fault on battery communications loss.
12. If communication still needs to be established, contact HomeGrid to ensure that the unit is on the latest firmware and configured for communication with Sol-Ark inverters

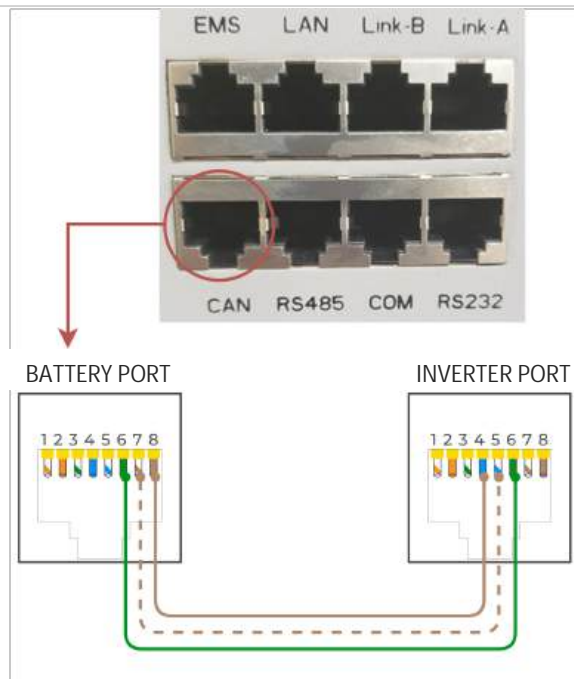

9. Incell / Polarium

Polarium



The provided information serves as general setup instructions for Polarium/Incell batteries and Sol-Ark inverters. Users are strongly advised to **consult the comprehensive technical documentation** provided by Polarium/Incell for specifications and settings to ensure optimal performance and safety. Visit the manufacturer's website and consult the relevant documentation below.



[Polarium/Incell documentation](#)



The Polarium Connect Bridge is required to communicate with Polarium/Incell 100/200 Ah battery banks.

You will need to make a custom cable for this setup. Use Inverter Comm >=143F.

Communications Installation and Setup Instructions

Connect all battery data ports using the included RJ45 cable, using the included terminator on the remaining port of either the first or last battery in the chain.

1. Connect the RJ45 cable attached to the Connect Bridge (pictured below) to the last open port on either the first or last battery in the chain. Insert the included terminator into the leftmost port on the front of the Connect Bridge.
2. Connect the power leads from the Connect Bridge to the battery terminals.
3. Turn on the breaker of each battery in the chain and power on one battery (it does not matter which) by holding the power button on the right side of the unit for about 5 seconds.
4. Using the Polarium Connect phone app (unreleased as of 8/2/2021), find and connect to the device labeled "Connect Bridge" within one minute of the connect bridge powering up.
 - Scan the QR code on the front of the Connect Bridge for the phone app to connect.
 - If you are connected, the "Incell" green led indicator on the front of the unit will stop flashing.
 - If you miss the one-minute connect window, you must power down the batteries entirely by flipping each breaker and holding the power button down for each one. Power the batteries back on and try again.
5. Under the "About Device" tab, ensure that the unit runs firmware version 0.3.8 or higher.
6. Under the "Configuration" tab, ensure that "Integrated Control" is enabled.
 - If it is not enabled, then enable it and reboot the connect bridge using the "Reboot" button under the "About Device" tab.
7. Create a custom cable such that Pin 1 (white-orange) on one end is connected to pin 5,

- Pin 2 (solid orange) on one end is connected to pin 4, and
Pin 6 (solid green) on one end is connected to Pin 6 (gnd).
8. Connect the end with pins 4, 5, and 6 used to the middle port on the Connect Bridge, and plug the other end with pins 1, 2, and 6 used to inverter port “Battery CAN Bus” (for outdoor units) or to the inverter port “RS-485” (for indoor units).
 9. On the inverter settings, enable “BMS Lithium Batt” and set its value to “03”.

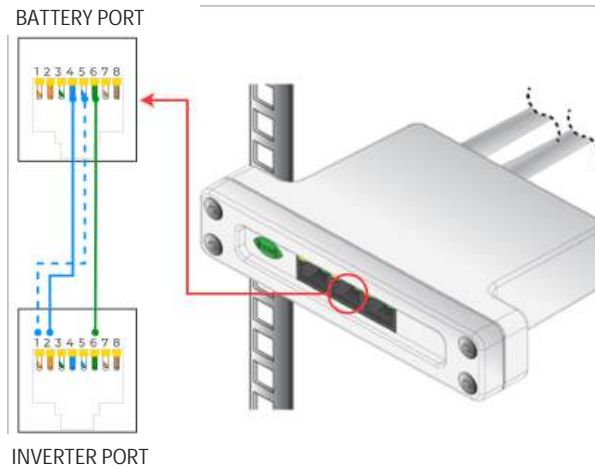

10. KILOVAULT HAB



The provided information serves as general setup instructions for Kilovault batteries and Sol-Ark inverters. Users are strongly advised to **consult the comprehensive technical documentation** provided by Kilovault for specifications and settings to ensure optimal performance and safety. Visit the manufacturer's website and consult the relevant documentation below.



[Kilovault documentation](#)



A custom cable is necessary for HAB V3 or older models. Use Inverter Comm >=143F

Communications Installation and Setup Instructions

1. Ensure that the batteries are running the latest firmware from Kilovault and that the Sol-Ark communication profile is selected.
 - If you need clarification, contact Kilovault to verify.
2. Set the DIP switches following the Kilovault manual.
 - If only using a single battery, all DIP switches should be “OFF.”
 - If using more than one battery, the battery connected to the inverter should have only DIP switch one (1) turned “ON.” Set DIP switches of all subsequent batteries according to what number they are in the chain (the DIP switches represent the binary number of the battery).
 - A theoretical maximum of 15 batteries can be communicating in parallel at the same time. More than one unit is still untested but should work.
3. (HAB V3 or older only) Create a custom cable such that the “Inverter RS485B” wire connects to pin 1 (white- orange) and “Inverter RS485A” connects to pin 2 (solid orange).

4. Connect the custom 6-pin connector to the KiloVault’s custom port and connect the custom RJ45 cable to the “Battery CAN Bus” (outdoor units) or “RS-485” (indoor units) port on the inverter.
5. Program the inverter with this battery’s appropriate charge/discharge settings.
6. Enable “BMS Lithium Batt” and set its value to “05”.
7. (Optional) Turn on “BMS_Err_Stop” if you wish for the system to fault on the loss of battery communications (This may happen more frequently since the KiloVault HAB batteries do not feature ground connections).

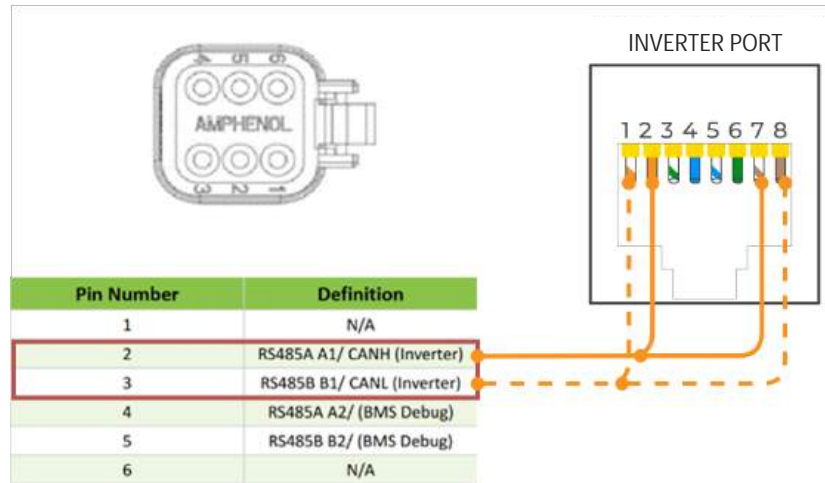

11. NuEnergy



The provided information serves as general setup instructions for NuEnergy batteries and Sol-Ark inverters. Users are strongly advised to **consult the comprehensive technical documentation** provided by NuEnergy for specifications and settings to ensure optimal performance and safety. Visit the manufacturer’s website and consult the relevant documentation below.



[NuEnergy documentation](#)

11.1 NuEnergy Lithium



You will need a custom RJ45 cable for this setup.

Communications Installation and Setup Instructions

1. Create a custom cable connecting pins 2, 3, and 4 ONLY (solid orange, white-green, and solid blue) to the battery.
2. Pin two (2) (solid orange) should connect to pin six (6) on the inverter.
3. Pin three (3) (white-green) should connect to pin five (5) on the inverter. Pin four (4) (solid blue) should connect to pin four (4) on the inverter.
 - On indoor units, leave pin two (2) (solid orange) connected to pin two (2) on the inverter instead of pin six (6).
4. Connect the cable to the “CAN” port on the NuEnergy cabinet and the “Battery CAN Bus” port (or the “CAN” port for indoor-only units) on the Sol-Ark.
 - The cable is NOT reversible; therefore, keep track of which end of the custom cable connects to the battery and the Sol-Ark.
5. Turn on the battery. Start by flipping the “ON” switch for every battery. Then, press the circular button at the top of the inside of the unit.
6. Program the inverter with this battery’s appropriate charge/discharge settings.
7. Enable “BMS Lithium Batt” and set its value to “00.”
8. (Optional) Turn on “BMS_Err_Stop” if you wish the system could fault on battery communications loss

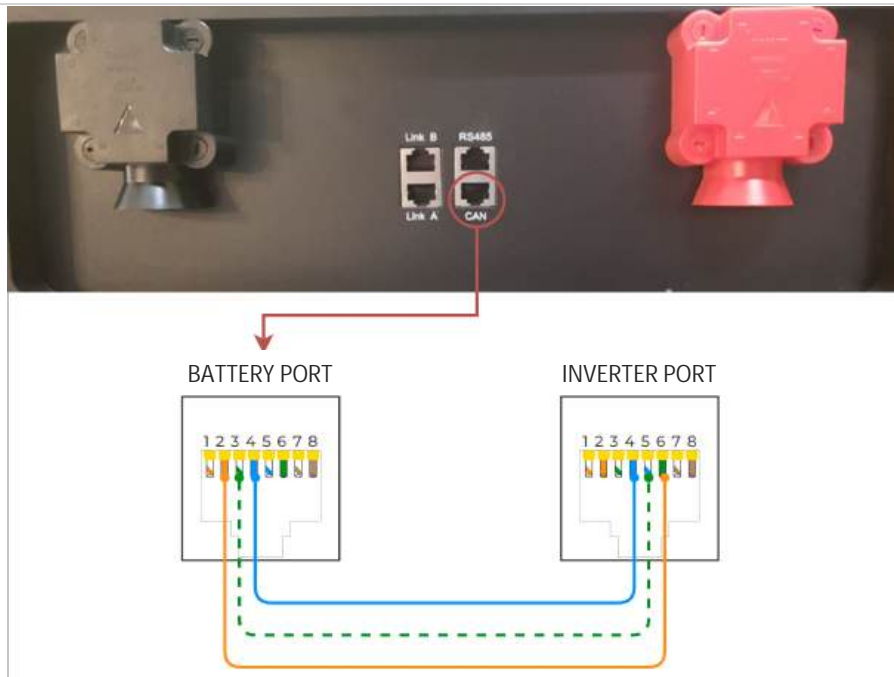

11.2 NuEnergy Lithium- Power Base M50



The provided information serves as general setup instructions for NuEnergy batteries and Sol-Ark inverters. Users are strongly advised to **consult the comprehensive technical documentation** provided by **NuEnergy** for specifications and settings to ensure optimal performance and safety. Visit the manufacturer's website and consult the relevant documentation below.



[NuEnergy documentation](#)



You will need a custom RJ45 cable for this setup.

Communications Installation and Setup Instructions

1. Create a custom cable that connects pins 6, 7, and 8 ONLY (solid green, white-brown, and solid brown) to the battery.
2. Pin six (6) (solid green) should connect to pin six (6) on the inverter.
3. Pin seven (7) (white-brown) should connect to pin five (5) on the inverter. Pin eight (8) (solid brown) should connect to pin four (4) on the inverter.
 - On indoor units, connect pin six (6) (solid green) to pin two (2) on the inverter instead of pin six (6).
4. Connect the cable to the "CAN" port on the NuEnergy and the "Battery CAN Bus" port (or the "CAN" port for indoor-only units) on the Sol-Ark.
 - The cable is NOT reversible; therefore, keep track of which end of the custom cable connects to the battery and the Sol-Ark.
5. Turn on the battery by pressing the power switch and holding it for 3 seconds. Then a display will light up, and the system will start to switch on all the battery systems.
6. Program the inverter with this battery's appropriate charge/discharge settings.
7. Enable "BMS Lithium Batt" and set its value to "00."
8. (Optional) Turn on "BMS_Err_Stop" if you wish the system could fault on battery communications loss

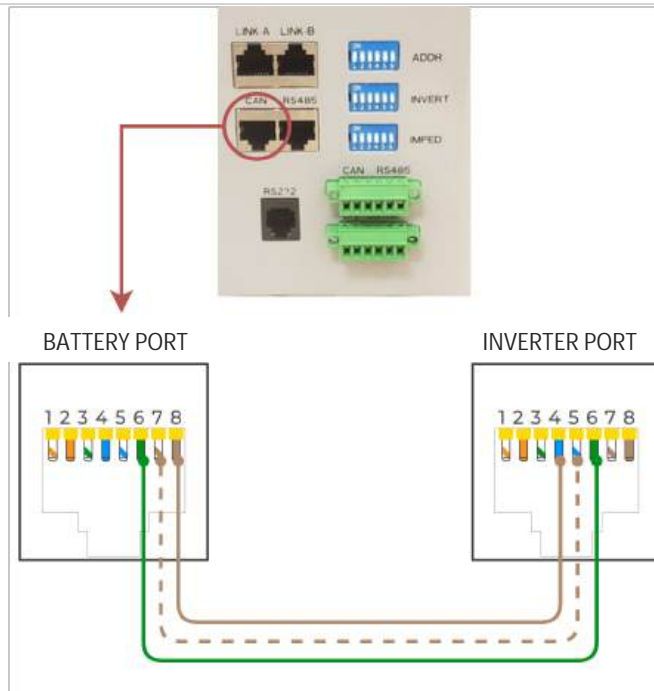

12. POWERSYNC 51.2V Lithium



The provided information serves as general setup instructions for PowerSync batteries and Sol-Ark inverters. Users are strongly advised to **consult the comprehensive technical documentation** provided by PowerSync for specifications and settings to ensure optimal performance and safety. Visit the manufacturer's website and consult the relevant documentation below.



[PowerSync documentation](#)

Communications Installation and Setup Instructions

1. Set the DIP switches on the battery per the manual and your battery configuration.
2. Connect all batteries with the included short RJ45 cables, connecting each battery via their RS485 ports.
3. CAN mode cable: Using a standard RJ45 connector-based CAT5/CAT6 Ethernet cable (all leads straight through), connect the master battery's "CAN" port to the inverter's "Battery CAN Bus" port (or to the inverter's "CAN" port for indoor-only units).
4. Turn on the batteries using the breaker labeled "Master Switch."
5. Program the inverter with this battery's appropriate charge/discharge settings.
6. Enable "BMS Lithium Batt" and set its value to "00."
7. (Optional) Turn on "BMS_Err_Stop" if you wish the system could fault on battery communications loss.

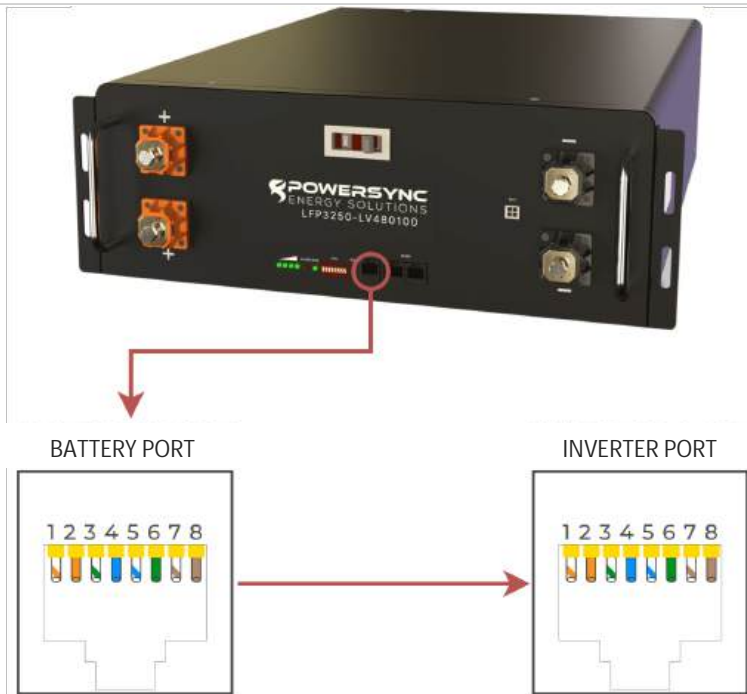

13. PYLONTECH US3000C



The provided information serves as general setup instructions for Pylontech batteries and Sol-Ark inverters. Users are strongly advised to **consult the comprehensive technical documentation** provided by Pylontech for specifications and settings to ensure optimal performance and safety. Visit the manufacturer's website and consult the relevant documentation below.



[Pylontech documentation](#)



You will need a custom RJ45 cable for this setup.

Communications Installation and Setup Instructions

1. Connect all batteries with the RJ45 cable from Link Port 1 to Link Port 0. The first battery with Link Port 0 empty would be the master battery. (Can use up to 16 batteries with 1 master battery and 15 slave batteries)
2. Set the ADD switch according to the battery manual if more than one string of batteries is in the battery bank.
3. Create a custom cable that connects pins 4, 5, and 6 ONLY (solid-blue, white-blue, and solid-green) to the battery.
4. Pin four (4) (solid-blue) needs to connect to pin four (4) on the inverter.
5. Pin five (5) (white-blue) needs to connect to pin five (5) on the inverter.
6. Pin six (6) (solid-green) needs to connect to pin six (6) on the inverter.
 - On indoor units, pin six (6) (solid-green) needs to connect to pin two (2) on the inverter.
7. Connect the cable to the "A/CAN" port on the Pylontech master battery and the "Battery CAN Bus" port (or the "CAN" port for indoor-only units) on the Sol-Ark.
 - The cable is NOT reversible for indoor units; therefore, keep track of which end of the custom cable connects to the battery and the Sol-Ark.
8. Program the inverter with the appropriate charge/discharge settings according to the specific battery manual.
9. Enable "BMS Lithium Batt" and set its value to "00".
10. (Optional) Turn on "BMS_Err_Stop" if you wish for the system to fault on the loss of battery communications (Pylontech recommend leaving the "BMS_Err_Stop" on to protect their batteries.

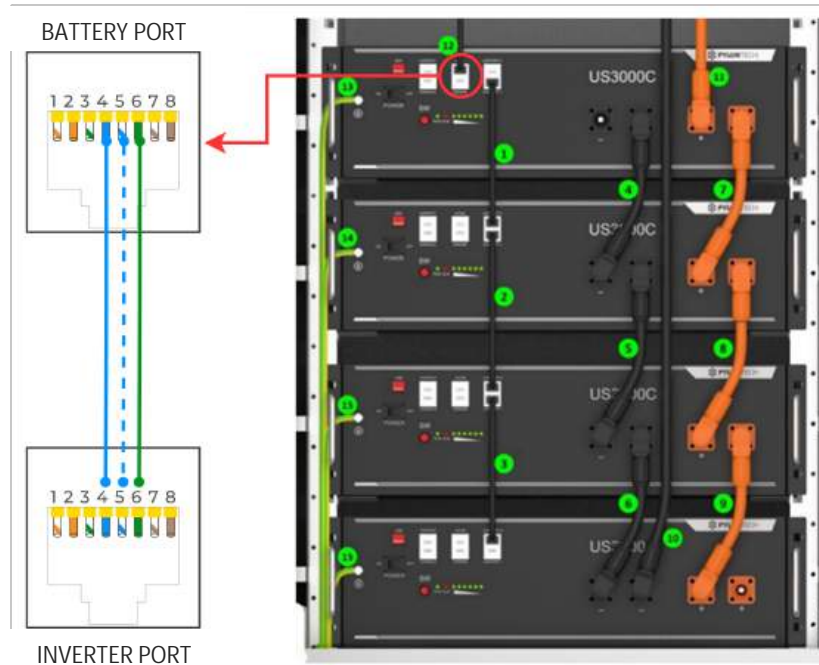

14. Pytes E-BOX-48100R

Pytes



The provided information serves as general setup instructions for Pytes batteries and Sol-Ark inverters. Users are strongly advised to **consult the comprehensive technical documentation** provided by Pytes for specifications and settings to ensure optimal performance and safety. Visit the manufacturer's website and consult the relevant documentation below.



[Pytes documentation](#)

Communications Installation and Setup Instructions

1. Connect all batteries with the provided RJ45 cable from Link Port 1 to Link Port 0. The first battery with Link Port 0 empty would be the host battery. (Can use up to 16 batteries with 1 master battery and 15 slave batteries)
2. Set the ADD switch according to the battery manual.
3. Connect the cable to the "CAN" port on the PYTES E-BOX host battery and the "Battery CAN Bus" port (or the "CAN" port for indoor-only units) on the Sol-Ark.
4. Program the inverter with the appropriate charge/discharge settings according to the specific battery manual and cable arrangement.
5. Enable "BMS Lithium Batt" and set its value to "00".
6. (Optional) Turn on "BMS_Err_Stop" if you wish for the system to fault on the loss of battery communications (PYTES recommends leaving the "BMS_Err_Stop" on to protect their batteries better).

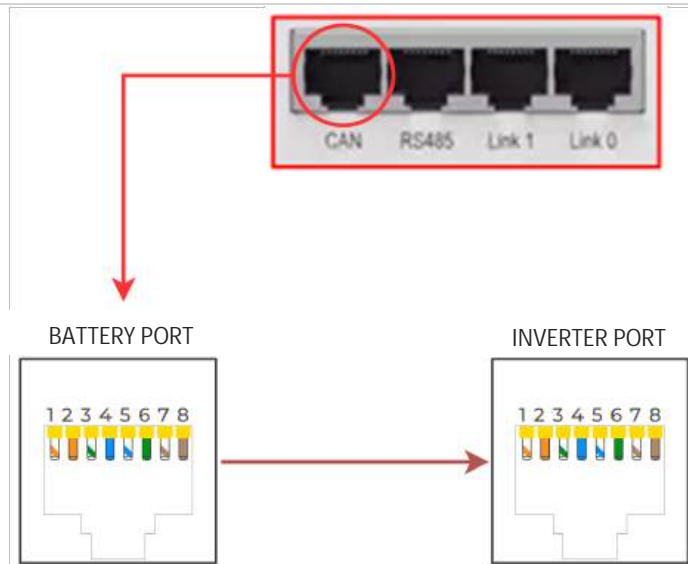

15. RENOZY AURA



The provided information serves as general setup instructions for RENOZY batteries and Sol-Ark inverters. Users are strongly advised to **consult the comprehensive technical documentation** provided by RENOZY for specifications and settings to ensure optimal performance and safety. Visit the manufacturer's website and consult the relevant documentation below.



[RENOZY documentation](#)

Communications Installation and Setup Instructions

1. Follow the instructions for installation and wiring in the battery manual.
2. Connect a standard CAT5/6 cable to the “485/CAN” port on the control box of the battery cluster and the “Battery CAN Bus” port (or the “CAN” port for indoor-only units) on the Sol-Ark.
3. Program the inverter with the appropriate charge/discharge settings according to the specific battery manual.
4. Enable “BMS Lithium Batt” and set its value to “00”.
5. (Optional) Turn on “BMS_Err_Stop” if you wish the system could fault on battery communications loss.

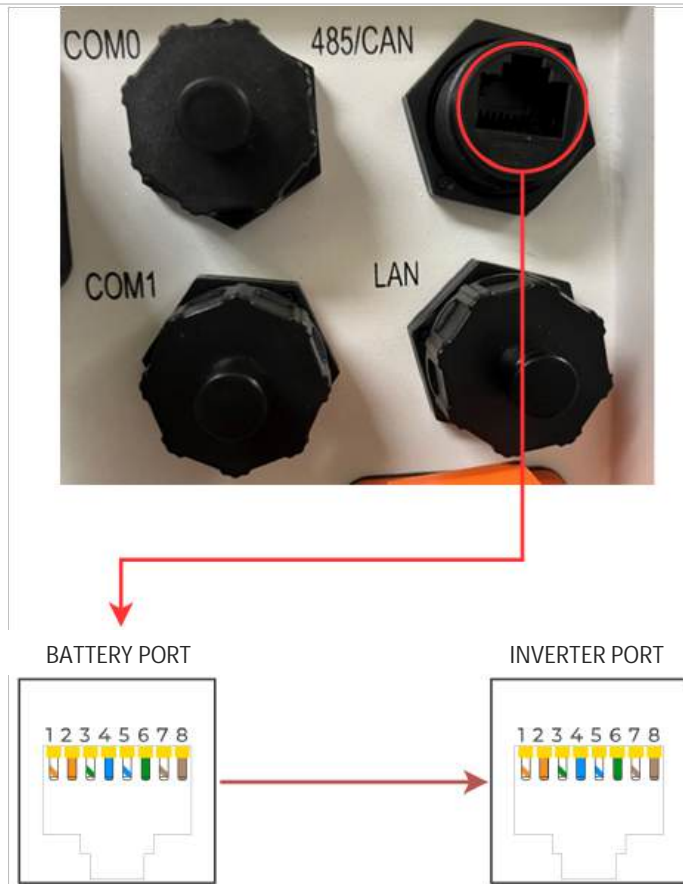

16. SACRED SUN LFP



The provided information serves as general setup instructions for Sacred Sun batteries and Sol-Ark inverters. Users are strongly advised to **consult the comprehensive technical documentation** provided by **Sacred Sun** for specifications and settings to ensure optimal performance and safety. Visit the manufacturer's website and consult the relevant documentation below.



[Sacred Sun documentation](#)

Communications Installation and Setup Instructions

- Use the DIP switches on the batteries such that the battery connected to the inverter is set as ID 1, and each unit behind it increases the follower ID to set DIP switches.
 - Each DIP switch (1-4) represents a bit in the follower ID value.
For example: 13 (decimal) = 1101 binary = [1: ON, 2: ON, 3: OFF, 4: ON].

Decimal counting from 0 to 15 in binary format as a 4-bit nibble (half byte):

0	1	2	3	4	5	6	7	8	9	10	11	12	13	14	15	dec
0000	0001	0010	0011	0100	0101	0110	0111	1000	1001	1010	1011	1100	1101	1110	1111	binary

2. Connect all batteries with the RJ45 cable such that they are all in parallel.
3. Create a custom RS485 mode cable that
Only uses battery pins 1 and 2 (white-orange, solid orange).
4. Battery end Pin 1 (white-orange) can be connected to inverter pin 1 or pin 8.
Battery end Pin 2 (solid orange) can be connected to inverter pin 2 or pin 7.
5. Connect this cable between the battery set as follower 1 and the inverter's port "Battery CANBus" (Outdoor models) or inverter port "RS-485" (on Indoor models).
6. Program the inverter with this battery's appropriate charge/discharge settings.
7. Enable "BMS Lithium Batt" and set its value to "01."
8. (Optional) Turn on "BMS_Err_Stop" for the system to fault on the loss of battery communications (This may happen more frequently since the Sacred Sun batteries do not feature ground connections).

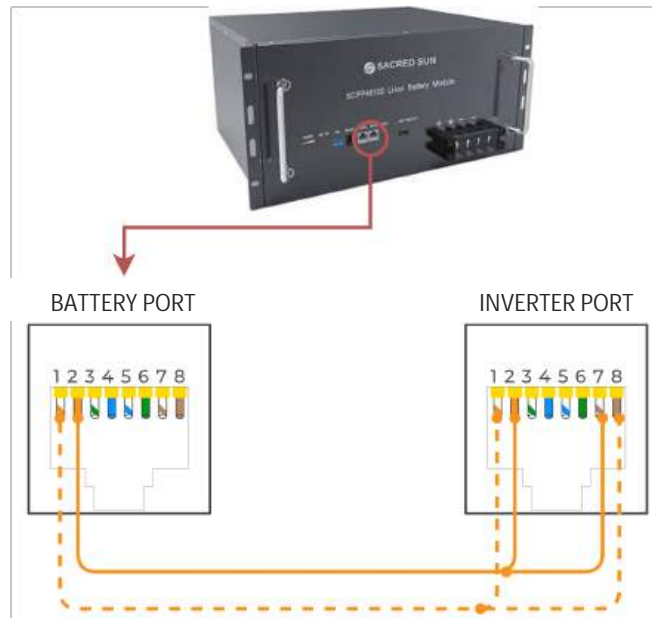

17. SOK



The provided information serves as general setup instructions for SOK batteries and Sol-Ark inverters. Users are strongly advised to **consult the comprehensive technical documentation** provided by SOK for specifications and settings to ensure optimal performance and safety. Visit the manufacturer's website and consult the relevant documentation below.



[SOK documentation](#)

Communications Installation and Setup Instructions

1. Connect all batteries together with the provided RJ45 cables using the "RS485B/RS485C" ports. Either port can be used for each battery. Up to 15 batteries can be connected in parallel.
2. Set the DIP switches such that the battery communicating with the inverter is set as ID 1, and each unit behind it increases the follower ID by 1 **from left to right**.
 - Each DIP switch (1-4) represents a bit in the follower ID value. For example: 13 (decimal) = 1101 binary = [1: ON, 2: OFF, 3: ON, 4: ON].

Decimal counting from 0 to 15 in binary format as a 4-bit nibble (half byte):

0	1	2	3	4	5	6	7	8	9	10	11	12	13	14	15	dec
0000	0001	0010	0011	0100	0101	0110	0111	1000	1001	1010	1011	1100	1101	1110	1111	binary

3. Connect a standard CAT5/6 cable between the "CAN" port on the Master battery and the "Battery CAN Bus" port (or the "CAN" port for indoor-only units) on the Sol-Ark.
4. Turn on the breakers of the batteries and inverter.
5. Use a thin tool to press in the "RST" button in any of the batteries to turn all of them on. You can now turn on the inverter if it is not on already.

6. Program the inverter with the appropriate charge/discharge settings according to the specific battery manual and cable arrangement.
7. Enable “BMS Lithium Batt” and set its value to “00”.
8. (Optional) Turn on “BMS_Err_Stop” if you wish for the system to fault on loss of battery communications.

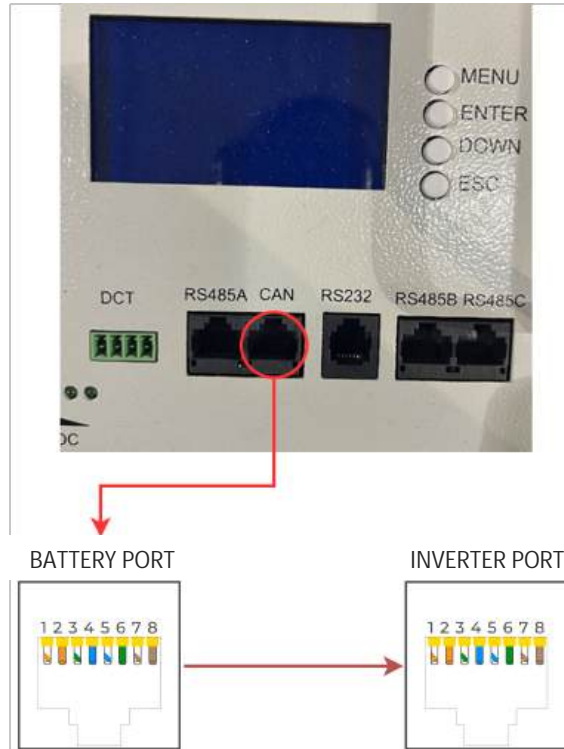

18. STORZ POWER



The provided information serves as general setup instructions for Storz Power batteries and Sol-Ark inverters. Users are strongly advised to **consult the comprehensive technical documentation** provided by **Storz Power** for specifications and settings to ensure optimal performance and safety. Visit the **manufacturer’s website** and consult the relevant documentation below.



[Storz Power documentation](#)



Make a custom cable as below or obtain it from Storz Power. Communications installation and setup instructions are updated for newer battery models on the Storz Power website

Comm Installation and Setup Instructions

1. Use the DIP switches on the batteries such that the battery connected to the inverter is set as follower 1 (0001), and each unit behind it shall increase the follower ID by one to be assigned. Each DIP switch (1-4) represents a binary digit (bit) in the follower ID with a value of 1 or 0.

Decimal counting from 0 to 15 in binary format as a 4-bit nibble (half byte):

0	1	2	3	4	5	6	7	8	9	10	11	12	13	14	15	dec
0000	0001	0010	0011	0100	0101	0110	0111	1000	1001	1010	1011	1100	1101	1110	1111	binary

For example: to set the DIP switch to decimal 13 = 1101 binary: [1: ON, 2: ON, 3: OFF, 4:ON]

2. Connect all batteries with the RJ45 cable such that they are all in parallel.
3. Create a custom cable that connects battery pins 1 & 2 only (white-orange & solid orange).

4. Battery comm pin 1 (white-orange) can be connected to inverter pin 1 or 8 (RS485-).
5. Battery comm pin 2 (solid orange) can be connected to inverter pin 2 or 7 (RS485+).
6. Connect this cable between the battery (set as follower 1) and the inverter's port "Battery CANBus" (Outdoor models) or port "RS-485" (on Indoor models). Either way, this is Modbus RTU RS485 mode.
7. Program the inverter with this battery's appropriate charge/discharge settings.
8. Enable "BMS Lithium Batt" and set its value to "01."
9. (Optional) Turn on "BMS_Err_Stop" if you wish for the system to fault on the loss of battery communications (This may happen more frequently since the Storz Power batteries do not feature ground connections (inverter port pin 6 is a gnd).

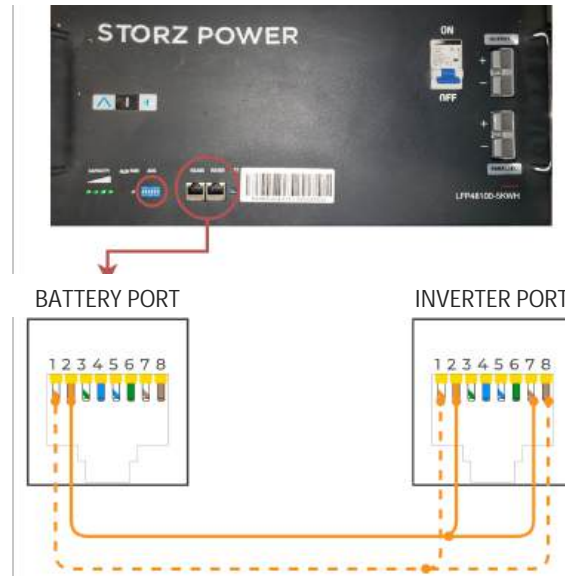

19. UZ ENERGY Power Lite (L051100-B)



The provided information serves as general setup instructions for UZ batteries and Sol-Ark inverters. Users are strongly advised to **consult the comprehensive technical documentation** provided by **UZ** for specifications and settings to ensure optimal performance and safety. Visit the manufacturer's website and consult the relevant documentation below.



[UZ documentation](#)



You will need a custom RJ45 cable for this setup.

Communications Installation and Setup Instructions

1. Connect all batteries with the provided RJ45 cable using the "RS485" ports. (Can use up to 16 batteries with 1 master battery and 15 slave batteries)
2. Set the ADD switch according to the battery manual and double check ADD switch settings before turning on the battery bank.
3. Create a custom cable that connects pins 1, 5, and 6 ONLY (white-orange, white-blue, and solid-green) to the battery.
4. Pin one (1) (white-orange) needs to connect to pin four (4) on the inverter.
5. Pin five (5) (white-blue) need to connect to pin five (5) on the inverter.
6. Pin eight (8) (solid-brown) need to connect to pin six (6) on the inverter.
 - On indoor units, pin eight (8) (solid-brown) need to connect to pin two (2) on the inverter.

7. Connect the cable to the “CAN/RS485” port on the UZ Energy Power Lite master battery and the “Battery CAN Bus” port (or the “CAN” port for indoor-only units) on the Sol-Ark.
 - The cable is NOT reversible; therefore, keep track of which end of the custom cable connects to the battery and the Sol-Ark.
8. Program the inverter with the appropriate capacity and charge/discharge settings according to the specific battery manual and cable arrangement.
9. Enable “BMS Lithium Batt” and set its value to “00”.
10. (Optional) Turn on “BMS_Err_Stop” if you wish the system could fault on battery communications loss.

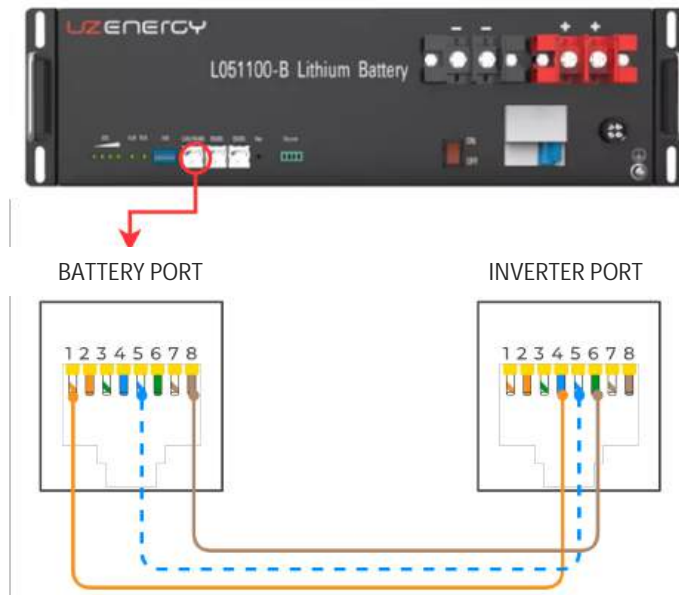

20. Volthium Energy



The provided information serves as general setup instructions for Volthium Energy batteries and Sol-Ark inverters. Users are strongly advised to **consult the comprehensive technical documentation** provided by Volthium Energy for specifications and settings to ensure optimal performance and safety. Visit the manufacturer’s website and consult the relevant documentation below.



[Volthium Energy documentation](#)

Communications Installation and Setup Instructions

1. Connect all batteries together with the provided RJ45 cables using the “Battery-Comm” ports. Either port can be used for each battery. Up to 15 batteries can be connected in parallel.
2. Set the DIP switches such that the battery communicating with the inverter is set as ID 1, and each unit behind it increases the follower ID by 1.

NOTE: Skip ID 2 (0010).

 - Each DIP switch (1-4) represents a bit in the follower ID value, from right to left. For example: 13 (decimal) = 1101 binary = [1: UP, 2: UP, 3: DOWN, 4: UP].

Decimal counting from 0 to 15 in binary format as a 4-bit nibble (half byte):

0	1	2	3	4	5	6	7	8	9	10	11	12	13	14	15	dec
0000	0001	0010	0011	0100	0101	0110	0111	1000	1001	1010	1011	1100	1101	1110	1111	binary

3. Connect a standard CAT5/6 cable between the “CAN” port on the Master battery and the “Battery CAN Bus” port (or the “CAN” port for indoor-only units) on the Sol-Ark.

4. Turn on the power buttons of the batteries.
5. Turn on the breakers of the batteries and inverter.
6. Use a thin tool to press in the "RST" button in any of the batteries to turn all of them on. You can now turn on the inverter if it is not on already.
7. Program the inverter with the appropriate charge/discharge settings according to the specific battery manual and cable arrangement.
8. Enable "BMS Lithium Batt" and set its value to "00".
9. Optional) Turn on "BMS_Err_Stop" if you wish for the system to fault on loss of battery communications

